

(No Model.)

2 Sheets—Sheet 1.

M. A. CHERRY.
VELOCIPÈDE.

No. 382,351.

Patented May 8, 1888.

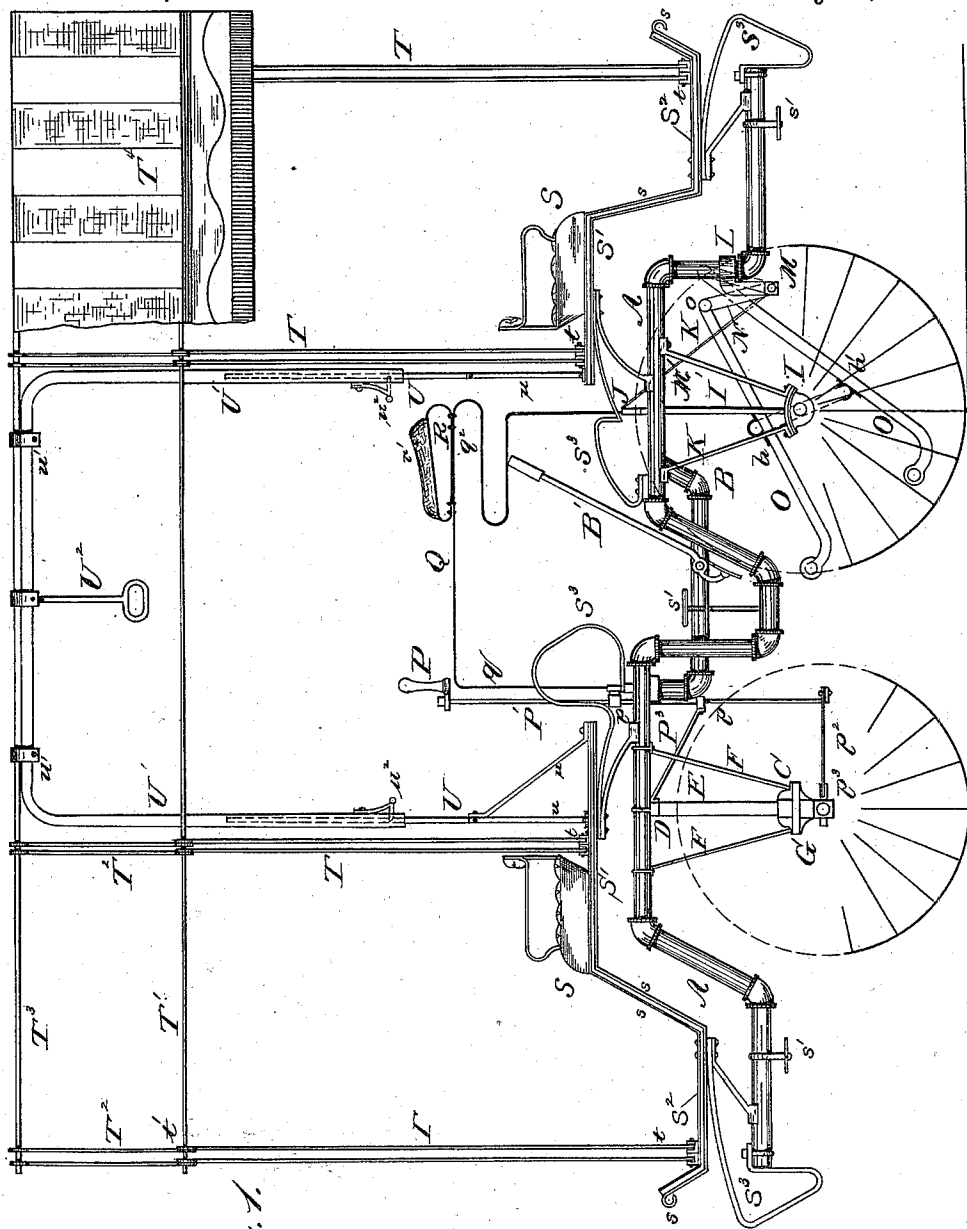

Fig. 1.

Witnesses.
Charles Lincoln
Ed Spinaud

Inventor.
Matthew W. Cherry
 By his Attorneys
Minot & Wright

M. A. CHERRY.
VELOCIPÈDE.

No. 382,351.

Patented May 8, 1888.

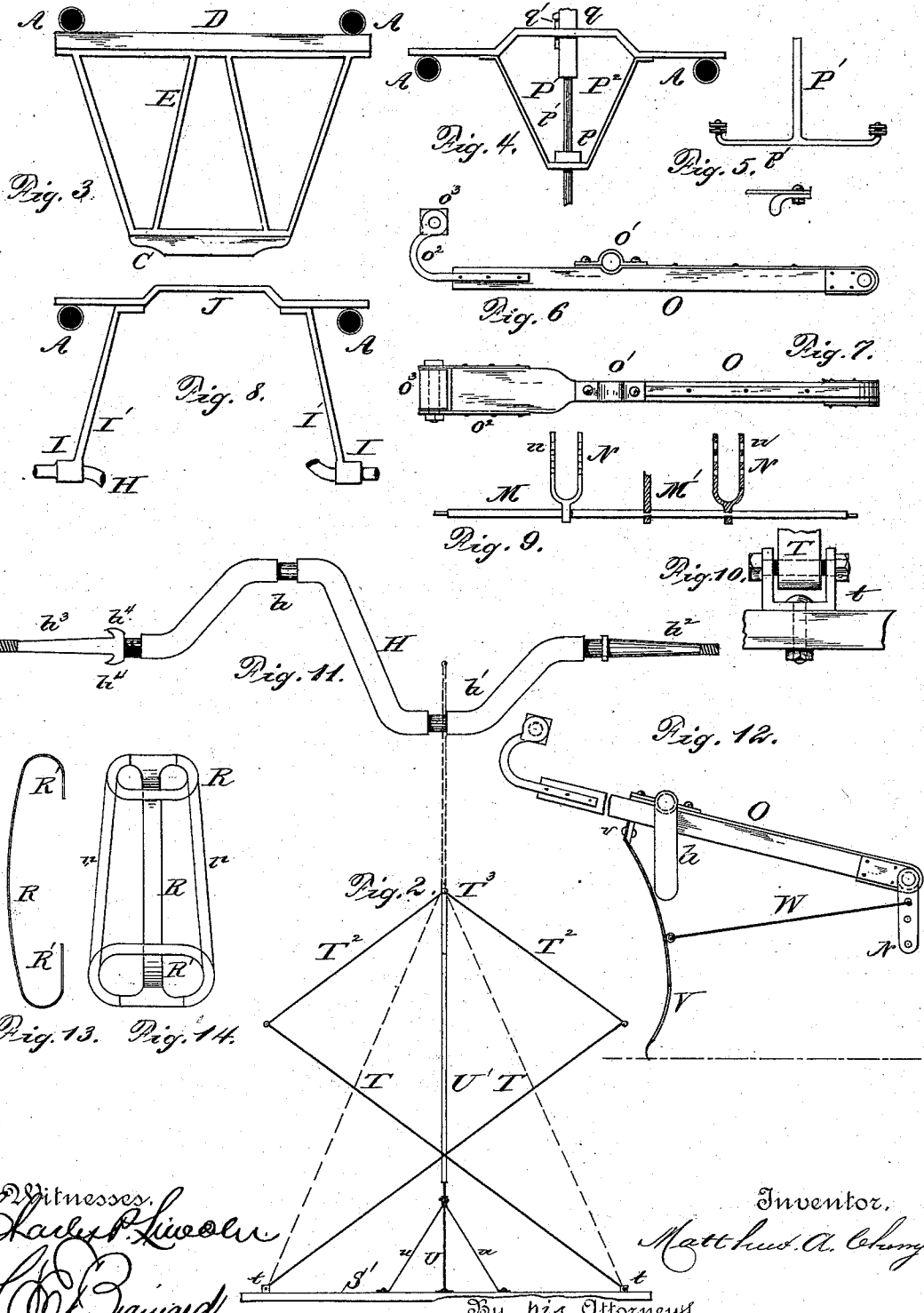

Witnesses,
Charles P. Lincoln
W. B. Rainard

Inventor,
Matthew A. Cherry
 By his Attorneys
Whittier & Wright

UNITED STATES PATENT OFFICE.

MATTHEW A. CHERRY, OF WASHINGTON, DISTRICT OF COLUMBIA.

VELOCIPEDE.

SPECIFICATION forming part of Letters Patent No. 382,351, dated May 8, 1888.

Application filed October 15, 1887. Serial No. 252,473. (No model.)

To all whom it may concern:

Be it known that I, MATTHEW A. CHERRY, a citizen of the United States, residing at Washington, in the District of Columbia, have invented certain new and useful Improvements in Velocipedes; and I do declare the following to be a full, clear, and exact description of the invention, such as will enable others skilled in the art to which it appertains to make and use the same, reference being had to the accompanying drawings, and to the letters and figures of reference marked thereon, which form a part of this specification.

My invention relates to velocipedes; and its object is to provide a vehicle capable of carrying three or more persons and adapted to be easily propelled by one of them.

The invention consists of certain combinations and arrangements of parts hereinafter described, and particularly pointed out in the claims.

In the accompanying drawings, Figure 1 is a side elevation of my improved velocipede. Fig. 2 is an end elevation of the awning; and Figs. 3 to 14, inclusive, are details of construction.

The same letters refer to corresponding parts in all the figures.

The frame A of the machine is composed of tubing, preferably in sections, united by couplings, though each side frame may, if desired, be formed from one piece of tubing bent to the required shape. The side frames are substantially M-shaped, as shown, the central U-shaped portion being strengthened by a piece, B, crossing it at about the middle. The angles of the frame may be still further strengthened by braces, if necessary.

The bolster C of the front axle, C, is united to the side frames by means of a cross-bar, D, secured to the side frames, and a W-shaped frame, E, between the bolster C and bar D. Braces F also run diagonally from near the center of the bolster to the side frames before and behind the frame E. The forward axle is provided with a fifth-wheel, G, to allow it to turn, as usual. The rear axle, H, is journaled in bearings I at the lower end of rods I', which are fastened to a slightly-arched cross-bar, J, secured to the frame A. Diagonal

braces K run from the bearings I to the frames A. The rear axle, H, is bent into two oppositely-disposed cranks, h h'. At one end it is provided with the usual tapering spindle, h². At the other end the spindle h³ is square, and at its base are formed two spurs, h⁴, which enter the hub of the wheel, and, together with the square spindle, compel the wheel to revolve with the axle.

Attached to the rear part of the frame A are two hangers, L, which support a rod, M, on which are loosely hung two forks, N. A rod, M', supports the middle of the rod M. In the arms of these forks are two or more perforations, n, for the pins o, by which the treadles O are pivoted to the forks. By having several holes n the range of movement of the pedals may be regulated. The treadles are preferably made of wood strapped with iron, as shown, and at about midway of their length is a suitable journal-bearing, o', to engage with the cranks h h'. Rising from each side of the outer end of the treadle is a curved standard, o², which furnish bearings for the pedal o³.

The steering-handle P is attached to the head of an upright shaft, P'. It consists of a cross-bar with a vertical handle at each end. The shaft P' is journaled in bearings p on a frame, P², fastened to the side frames, A. A brace, P³, runs from the lower bearing to the center of the cross-bar D. At the lower end of the shaft P' is a cross-bar, p', to the ends of which are jointed links p², connecting the cross-bar with forked bolts p³, secured to the forward axle, C, near its ends. Upon turning the handle-bar P the front axle will be turned accordingly.

The seat for the rider is supported on a bar, Q, which at its forward end has a downwardly-extending portion, q, passing through a slot in the frame P² and secured at any desired height by a key, q'. Under the seat the bar is bent into the shape of a reversed S to form a spring, q², and is then extended downward through a slot in the cross-bar J, in which it is secured by a key.

The seat-frame is formed as shown in Figs. 13 and 14, being composed of a strip, R, of sheet metal, preferably steel, bent up at each end and having open semicircular heads R', to

which is riveted or otherwise secured a saddle, *r*, of leather, upon which is secured the cushion *r'*. The strip R is fastened to the bar Q over the spring *q*² either permanently or adjustably, as desired. The seat-frame is made by forming a slit in each end of a strip of metal, then bending the two parts of the slitted portion away from each other, bringing the ends around until they meet, and welding them together, thus forming a ring either circular, elliptical, or any desired shape, and then turning the ends of the strip up and over until the rings lie substantially in a plane parallel with the main portion of the strip and a few inches above the same, as shown in Figs. 13 and 14.

The seats S for passengers are supported on platforms S', which are provided with foot-rests S² and are mounted on suitable springs, S³. The platforms and foot-rests are strengthened by iron straps *s*, and are located at the front and rear of the machine, preferably facing in opposite directions, as shown. Steps *s'* afford easy access to all the seats.

Within easy reach of the operator is a brake-handle, B', pivoted to the strap B and acting upon the driving-wheel.

Suitable wheel-guards may be attached to the frame A, if desired.

To protect the occupants of the vehicle from the sun and rain, an awning is spread over the whole machine. It is composed of uprights T, disposed in four pairs, the two uprights in each pair crossing like the letter X. The feet of the two end pairs are hinged in forked standards *t*, secured to the foot-rests S². The other pairs of uprights are similarly hinged to the platforms S' in the rear of the seats S. At the upper ends of the uprights T are formed eyes *t'*, through which pass horizontal rods T', which also pass through similar eyes in the ends of shorter rods T², extending from the side rods, T', to a middle rod or ridge-pole, T³, the rods T² forming rafters to support the awning-cover T⁴.

On each platform S', behind the inner pair of uprights T and in the center line of the machine, is a vertical standard, U, firmly braced by suitable struts, *u*. On each standard slides a tube, U', which at its upper end is fastened to the ridge-pole T³ of the awning. In the drawings the sliding tubes are shown as formed of a piece of gas-pipe bent into an inverted-U shape and attached to the ridge-pole by clips *u'*. At the center is a handle, U², by which the rider can raise or lower the ridge-pole, the sliding tubes U' being provided with suitable spring-catches or other fastening devices, *u*², to engage with notches in the standards U and hold the awning at any desired height. When the handle U² is pushed up, the side rods, T', rise and approach each other until finally they meet at a line directly over the standards U, as shown in dotted lines in Fig. 2. In this position the awning-cover is folded together in a vertical flat collapsed con-

dition, sufficiently far above the heads of the occupants to allow them to get on or off without impediment.

To enable the machine to be propelled upon snow or ice, I may provide each treadle with a sharp-pointed pusher, V, Fig. 12, made of spring metal and pivoted to the treadle at *v*. A rod, W, having one end connected to the fork N and the other to an eye at the middle of the pusher V, causes the end of the pusher to vibrate as the crank *h* revolves, and thereby impart a forward motion to the machine.

Having thus described my invention, what I claim, and desire to secure by Letters Patent, is—

1. In a velocipede, the combination, with the M-shaped tubular frame A, of the bolster C', the cross-bar D, the frame E, the bearings I and rods I', and the cross-bar J, substantially as set forth.

2. In a velocipede, the combination, with the M-shaped tubular frame A, of the seats S, platforms S', foot-rests S², and the springs S³, substantially as set forth.

3. In a velocipede, the combination, with the cranked axle H, of the rod M, the forks N, loosely hung on said rod and provided with two or more perforations, *n*, and the treadles O, pivoted in said forks and having the bearings *o'* and pedals *o*³, substantially as set forth.

4. In a velocipede, the combination, with the M-shaped frame A, of the bolster C', cross-bar D, and frame E, the front axle, C, turning on the bolster C', the frame P², the vertical shaft journaled in bearings on said frame and having at its upper end the handles and at its lower end the cross-bar, and the links connecting said cross-bar with the front axle, substantially as set forth.

5. In a velocipede, the combination, with the M-shaped tubular side frame, A, of the frame P², the cross-bar J, and the bar Q, carrying the seat and having a spring portion, *q*², and downwardly-extending ends passing through slots in frame P² and cross-bar J, and adjustably secured therein, substantially as set forth.

6. In a velocipede, the seat R, composed of a strip of metal turned upward and over at each end and provided with open heads, the leather saddle *r*, secured to said heads, and the cushion *r'*, secured to said saddle, substantially as set forth.

7. The method of making a velocipede-seat frame, which consists in slitting a portion of each end of a strip of metal, bending the two parts of the slitted portion into a ring and welding the ends together; and then turning each of said ends up and over until the rings lie in a plane parallel with the main portion of the strip and a few inches above the same, substantially as set forth.

8. The combination, with a velocipede, of the uprights T, hinged at their lower ends, the side rods, T', the rafters T², and the ridge-pole T³, substantially as set forth.

9. The combination, with a velocipede, of the crossed uprights T, hinged at the lower end, the side rods, T', the rafters T², and ridge-pole T³, the standards U, and the sliding tubes U', attached to the ridge-pole T³, substantially as set forth.

W, connecting the middle of the pusher with the fork N, substantially as set forth. ¶

In testimony whereof I affix my signature in presence of two witnesses.

MATTHEW A. CHERRY.

Witnesses:

ROBINSON WHITE,
FRANK G. MATTINGLY.

10. In a velocipede, the combination, with the fork N, treadle O, and crank h, of a spring-pusher, V, pivoted to the treadle, and a rod,