

(No Model.)

2 Sheets—Sheet 1.

C. B. BROOKS.
STREET SWEEPER.

No. 556,711.

Patented Mar. 17, 1896.

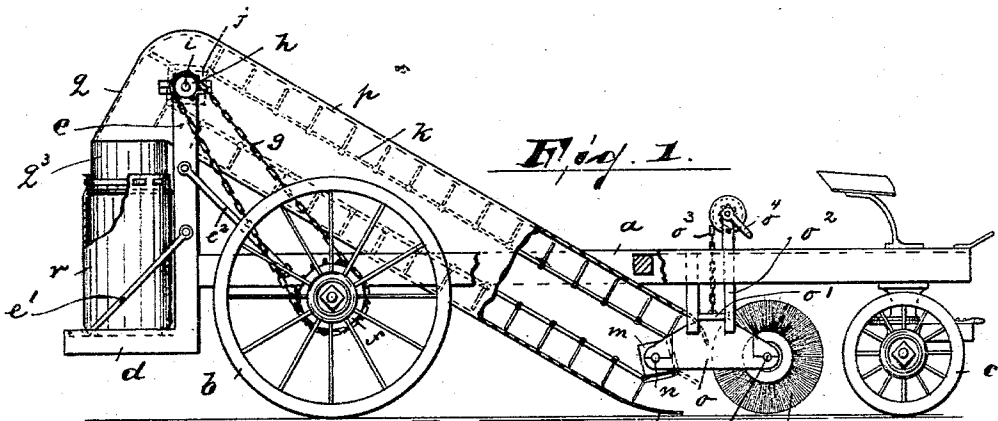

Fig. 1.

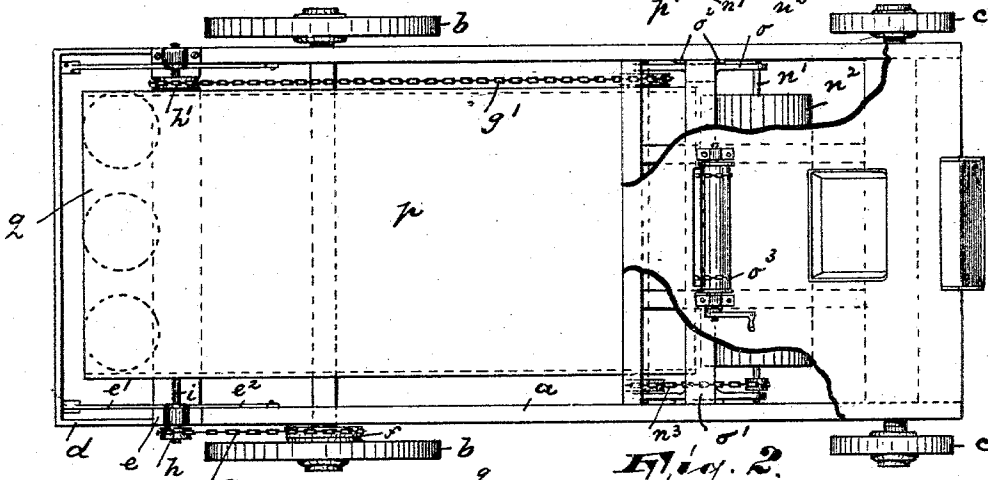

Fig. 2.

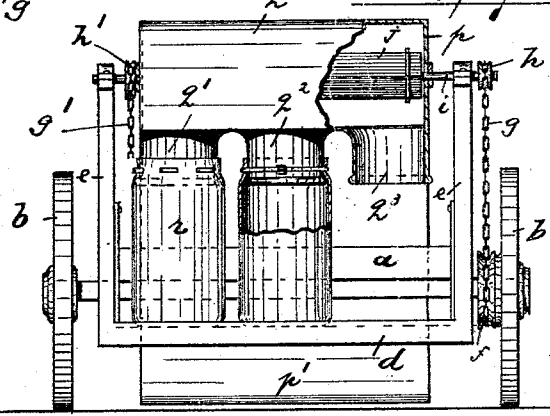

Fig. 3.

WITNESSES:

Arthur H. Thomson
Runcan M. Robertson

INVENTOR:

Charles B. Brooks

BY *Partner & Co*

ATTORNEYS.

(No Model.)

2 Sheets—Sheet 2.

C. B. BROOKS.
STREET SWEEPER.

No. 556,711.

Patented Mar. 17, 1896.

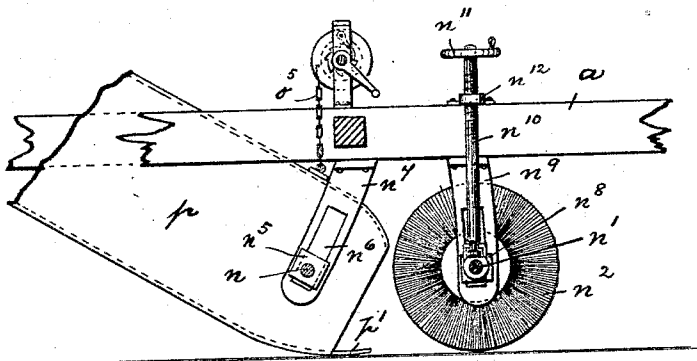

Fig. 4.

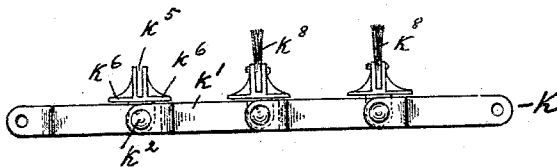

Fig. 5.

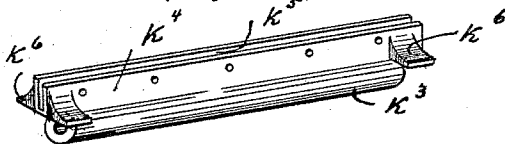

Fig. 6.

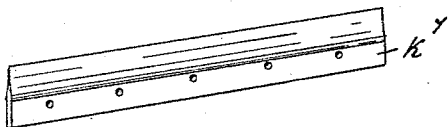

Fig. 7.

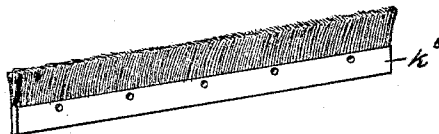

Fig. 8.

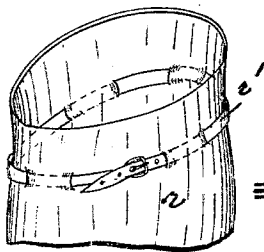

Fig. 9.

WITNESSES:

Arthur H. Thomson.
Runcan W. Robertson.

INVENTOR:

Charles B. Brooks

BY

Partners & Co

ATTORNEYS.

UNITED STATES PATENT OFFICE.

CHARLES B. BROOKS, OF NEWARK, NEW JERSEY, ASSIGNOR OF TWO-THIRDS TO PLUMMER S. PAGE AND GEORGE M. HALSTEAD, OF SCRANTON, PENNSYLVANIA.

STREET-SWEEPER.

SPECIFICATION forming part of Letters Patent No. 556,711, dated March 17, 1896.

Application filed April 29, 1895. Serial No. 547,455. (No model.)

To all whom it may concern:

Be it known that I, CHARLES B. BROOKS, a citizen of the United States, residing in Newark, county of Essex, and State of New Jersey, have invented certain new and useful Improvements in Street Sweepers or Cleaners; and I do hereby declare the following to be a full, clear, and exact description of the invention, such as will enable others skilled in the art to which it appertains to make and use the same, reference being had to the accompanying drawings, and to letters of reference marked thereon, which form a part of this specification.

The object of this invention is to improve the kind of street-sweeper and cleaner which involves a revoluble brush, elevating mechanism and refuse-receptacles.

The invention consists in certain details which will hereinafter be more fully described in the specification and embodied in the clauses of the claim.

Referring to the accompanying drawings, in which like letters of reference indicate corresponding parts in each of the several views, Figure 1 is a side elevation of my improved street sweeper and cleaner, certain portions being removed. Fig. 2 is a top plan view of the apparatus with certain portions removed or broken away. Fig. 3 is a rear end view of the apparatus, partly in section. Fig. 4 illustrates a modified form of the lifting mechanism for the sweeper and elevator casing, slightly enlarged. Figs. 5, 6, 7, and 8 are enlarged detail views of the elevatory chain and its buckets and bucket-holders, and Fig. 9 is an enlarged detail view of the upper portion of one of the receiving-bags.

In said drawings, *a* is a truck-frame, mounted on the axles which are supported by the rear and front wheels, *b* and *c*. One of the said rear wheels, *b*, is a drive-wheel for both the elevatory and the sweeping mechanisms. It is provided at its hub with a sprocket-wheel *f*, upon which travels an endless chain *g*, which, reaching upward, engages another sprocket-wheel *h* secured to a journal *i*. Said journal *i* carries a squared shaft *j* and is mounted at both its ends in bearings in the upper extremities of a pair of upright standards *e*, comprising the rear portion of the

truck-frame *a* and supported by braces *e*², which extend from the said standards to the truck-frame.

To the end of the journal *i* opposite that which carries the sprocket-wheel *h* another sprocket-wheel, *h'*, is attached, which engages the links of an endless chain *g'*. The sprocket-wheel *h'* transmits its motion through said chain *g'* to a sprocket-wheel on journal *n*, provided with a squared shaft *m* corresponding to shaft *j* on journal *i*.

The bearings for the journal *n* are in the frame-plates *o*, situated on both sides of the machine and under the truck-frame near the front wheels.

On the end of journal *n* opposite that which carries the aforesaid sprocket-wheel is a sprocket-wheel which transmits motion through a chain *n*³ to a sprocket-wheel secured on a shaft *n'*.

The shaft *n'* has bearings in the frame-plates *o* corresponding to those of the journal *n*, and it constitutes an axle for a revoluble brush *n*².

The frame-plates *o*, together with the apparatus mounted therein, may be raised and lowered by means of two chains *o*³, fastened at their lower ends to a bridge *o'* connecting and surmounting the two frame-plates, and said chains *o*³, at their other ends, wind upon a drum operated by a crank *o*⁴. This drum is mounted in the upwardly-extending ends of two of the guides *o*² for the frame-plates.

To the journal *i* of the squared shaft *j* is pivoted the elevator casing or chute *p* by means of holes, which are in the sides of said casing or chute at its upper end, through which said journal extends. At the lower end of the aforesaid elevator-casing is a pan *p'*, which, as shown, is a continuation of the casing or chute and projects considerably forward of the shaft *m*.

Over the squared shafts *j* and *m* pass endless elevatory chains *k*, provided with bucket-holders *k*⁴ and buckets *k*⁵ or *k*⁶, which will hereinafter be more fully described. These elevatory chains are mounted so that their links always come squarely into contact with the faces of the squared shafts *j* and *m* as they revolve, or, in other words, the junctures of the links *k*' as they pass around come

into coincidence with the corners of the said squared shafts.

The bucket-holder k^4 , Figs. 4 and 5, comprise three distinct features—a sleeve k^3 , a longitudinally-extending slot k^5 , and lugs k^6 , situated at both ends and on both sides of the holders. Through the sleeve k^3 extends a rod k^2 , carrying the bucket-holder which serves to space the chains k .

The slot k^5 is so constructed as to be capable of receiving interchangeably either of the two buckets illustrated in Figs. 7 and 8, and the lugs k^6 are adapted to rest upon the links of the said elevatory chains k .

The construction of the buckets involves a scraper k^7 or a brush k^8 , either of them being adapted to fit the same bucket-holder and to be held therein by bolts extending through corresponding holes in both the bucket-holder and its bucket.

Below a channel q , terminating the upper end of the elevator-chute p , a series of hoppers q' q^2 q^3 extends downward. These hoppers communicate with the mouths of a corresponding series of bags r buckled around the said hoppers by means of a strap r' interlaced in each bag. The said bags are carried by a platform d , secured beneath and to the upright standards e and supported by braces e' connecting the platform and the said upright standards.

In the construction above described the shafts n and n' can only be raised together, but in Fig. 4 a modification is shown which allows said shafts to be adjusted independently of each other.

The shaft n has its bearings in a bushing n^5 secured to the side of the elevator chute or casing and guided in a slot n^6 of a bracket n^7 , which latter is arranged in the arc of a circle concentric to the shaft i . To the bushing or to the casing p is secured one end of a chain o^5 , by which said casing and its shaft can be raised and lowered.

The shaft n' has its bearings in the bushing n^8 , which is guided in a slotted bracket n^9 , projecting downward from the truck-frame a .

In the top of each bushing is swiveled the headed end of an elevatory screw n^{10} . The screw n^{10} is provided with a hand-wheel n^{11} and operates in an internally-threaded block n^{12} fixed to the truck-frame a .

In operation the refuse is swept by the revoluble brush n^2 into the lower end of the elevator-chute p , from whence it is carried upward through the chute by the buckets mounted upon the elevatory chains. Passing through the upper end of said elevatory chute it falls through the channel q and hoppers q' q^2 q^3 into bags r , which when filled are replaced by empty ones.

The particular elevator-casing with its elevatory mechanism which I have described gives the machine many obvious advantageous functions. One of the points to be kept in view in constructing a sweeper is that it should be dust-proof as well as capable of

thoroughly cleaning the street. To this end the mouth of the elevator-casing at its lower end in my sweeper is restricted in size. This mouth is formed by gradually curving the upper and the lower sides of the chute or casing toward each other. The upper edge of this opening is situated close to the revoluble brush and the lower edge is in close proximity to the ground, so that the downward curving of the upper side of the casing tends to shut in the dust stirred up by the action of the different mechanisms. The pan p' projecting from this edge is, as heretofore stated, a continuation of the lower side of the chute, and is so situated as to catch practically all the refuse thrown by the revoluble brush.

The upper end of the elevator-casing is made dust-proof by securing the bags tightly to the hoppers by means of the straps interlaced in the bags, as hereinbefore described. The hoppers and the chute q constituting the terminus of the elevator-casing are made continuous with the casing, so that there is no opening left for the escape of the dust.

To aid in keeping the elevatory apparatus free from adhering refuse which is apt to travel back to the lower end of the casing and there fall out and raise a dust, the chains k are made so that each link as it comes into contact with a face of the squared shaft j will, by means of the successive blows delivered by these two squared shafts upon the links of the elevatory apparatus, be freed of most of the dirt which clings to it. The refuse which is loosened at the lower squared shaft m , if any there be, will fall into the pan p' , to be again elevated. Any dirt loosened at the upper squared shaft falls through the chute q and its hoppers into the bags r .

The arrangement which allows of mounting the brushes or scrapers interchangeably renders the elevatory mechanism applicable for both heavy and light work. The scrapers may be used to elevate snow, pieces of ice, and stone, and the brushes are suitable for the ordinary cleaning of streets. Their holders are both adapted to carry the buckets in an upright position and to serve to space the chains. Their position at the ends of the links allows of their being mounted on the rod connecting the chains and joining the links thereof.

The modifications allow of the adjustment of the revoluble brush and elevator-casing independently, which under certain circumstances would be very advantageous. The journal i at the upper end of the casing is both an axle upon which the latter is fulcrumed and a means for transmitting power from one element to another element of the machine.

Having thus described my invention, I claim as new and desire to secure by Letters Patent—

1. In a sweeper the combination of a supporting-frame, a shaft carried by said frame, an inclined elevator-casing fulcrumed at its

upper end upon said shaft, a shaft mounted in the lower end of the casing elevatory chains and buckets carried by the shafts, guide-brackets on each side of said elevator-casing and secured to the truck-frame, bushings attached to the sides of said casing, and adapted to move in the guide-brackets, and means for adjusting the lower end of said casing, substantially as described.

10 2. The combination with elevatory chains, of rods connecting said chains, said rods also serving to join the links of each chain, bucket-holders carried by said rods and serving to space the chains and buckets constructed to be mounted in said bucket-holders, substantially as described.

15 3. The combination with a bucket-holder having a slot on its upper side, a sleeve on its lower side and lugs at its ends upon both sides thereof, of two perforated elevatory chains from the one to the other of which

two chains, the bucket-holder extends, and a rod extending through the sleeve of the bucket-holder and through a hole in each of the chains, substantially as described. 25

4. The combination with a bucket-holder having a slot on its upper side, a sleeve on its lower side and lugs at its ends upon both sides thereof, of two elevatory chains having overlapping links with coincident holes, from one to the other of which two chains the bucket-holder extends, and a rod extending through the sleeve of the bucket-holder and through the aforesaid holes in the links, substantially as described. 30

In testimony that I claim the foregoing I have hereunto set my hand this 11th day of April, 1895. 35

CHARLES B. BROOKS.

Witnesses:

ALFRED GARTNER,
WM. D. BELL.