

P. B. DOWNING.  
STREET RAILWAY SWITCH.

No. 430,118.

Patented June 17, 1890.

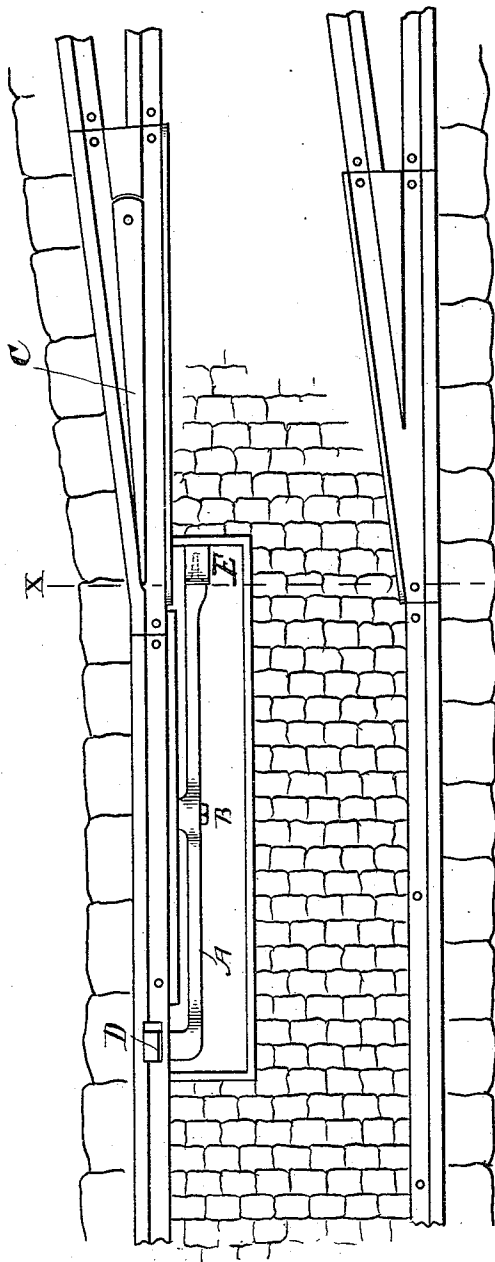

FIG. 1.

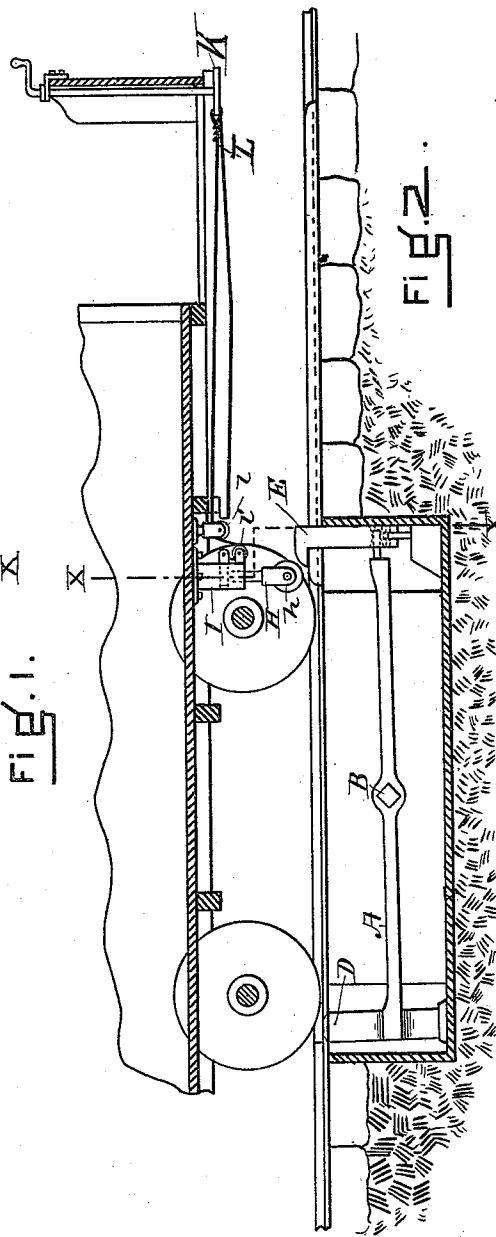

FIG. 2.

WITNESSES

*Ellen B. Tomlinson.*  
*John H. Taylor.*

INVENTOR

*Philip B. Downing.*  
*by Alex. P. Browne*  
*attorney.*

P. B. DOWNING.  
STREET RAILWAY SWITCH.

No. 430,118.

Patented June 17, 1890.

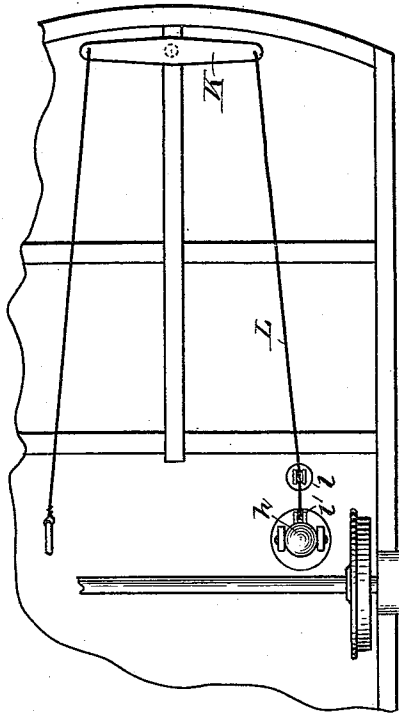

FIG. 6.

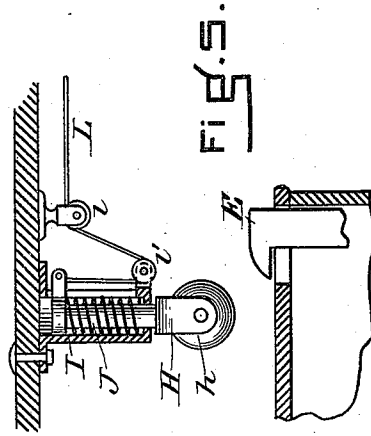

FIG. 5.

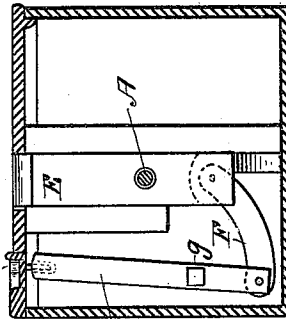

FIG. 4.

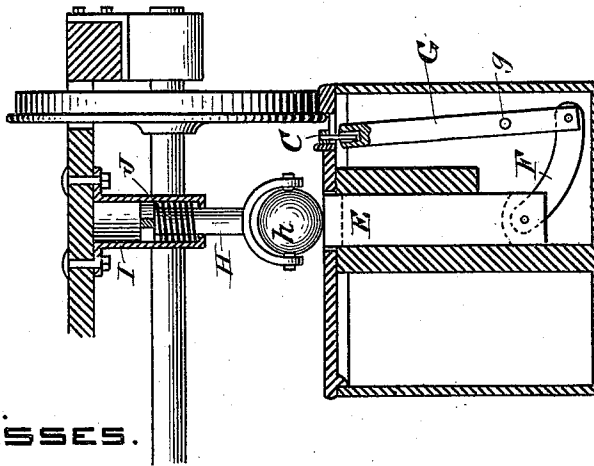

FIG. 3.

WITNESSES.

*Ellen B. Tomlinson*  
*John H. Taylor.*

INVENTOR

*Philip B. Downing*  
*by Alex. P. Browne,*  
*attorney.*

# UNITED STATES PATENT OFFICE.

PHILIP B. DOWNING, OF BOSTON, MASSACHUSETTS.

## STREET-RAILWAY SWITCH.

SPECIFICATION forming part of Letters Patent No. 430,118, dated June 17, 1890.

Application filed February 17, 1890. Serial No. 340,804. (No model.)

*To all whom it may concern:*

Be it known that I, PHILIP B. DOWNING, of Boston, in the county of Suffolk and State of Massachusetts, a citizen of the United States, have invented certain new and useful Improvements in Street-Railway Switches, of which the following is a specification.

My invention relates to that class of street-railway switches in which the switch-tongue is operated by mechanism worked from the vehicle traveling upon the railway or by the vehicle itself; and its object is to improve the construction of these devices in certain respects, as will be hereinafter more fully set forth.

In the accompanying drawings I have represented an embodiment of my invention in the form now best known to me. In the drawings, Figure 1 is a plan view of a portion of a track and switch in connection with which the device is to be used. Fig. 2 is a vertical section of the same with the addition of a portion of the car in place and about to operate the switch to shunt the car onto a siding. Figs. 3 and 4 are enlarged views in cross-section upon the section-lines  $x x$  and  $y y$  of Fig. 1. Fig. 5 is a view in section of the switch-operating mechanism hereinafter described; and Fig. 6 is a plan view of the under side of a car and platform, showing this mechanism and its connections as arranged thereon.

In the drawings, A represents the tilting switch-lever, which is pivoted at B to the side of a vertical case or excavation adapted to be sunk between the rails below the level of the street, the forward end of this excavation terminating substantially at the point of the switch-rail C. The vertical tilting of the lever A around its center B regulates the position of this switch-rail and opens and closes the switch. At the rear end of the lever A is an upward extension D, (see Fig. 1,) which works upwardly through or past the rail and within the normal line of tread of the wheels of the car or other vehicle running thereon. This projection, when the switch is set closed or in the position shown in Fig. 1, does not project above the surface of the rail, the rear end of the lever A being normally its depressed end.

I use the word "open" throughout this

specification in the sense of "set to the siding" and the word "close" in the sense of "set to the main track."

The forward end of the lever A also carries a vertical extension E, which projects upwardly above the surface of the rail, but on a line a little inside of the path of the wheel of the vehicle. The position of this projection E relatively to the track of the wheel of the vehicle is seen at Fig. 3, which is a vertical section looking rearwardly on the line  $x x$  of Fig. 2, Fig. 4 being a similar section looking forward on the line  $x x$  of Fig. 1. This vertical projection E preferably consists of a block adapted to slide vertically, as shown, and connected at its lower end by means of a link F, (see Figs. 3 and 4,) with a lever G, adapted to oscillate at right angles to the main line of track around its pivot  $g$ . The upper end of this lever is loosely connected, as by a pin and slot, as shown, with the free end of the switch-rail C. As will be perceived by the drawings, depressing the block E will move the switch-rail inward, thereby opening the switch, and elevating the block E would move the switch-rail outward, thereby closing the switch and leaving the track open. To depress this projection E and open the switch, any suitable device may be employed. I prefer, however, to use for this purpose an arm H, depending from the under side of the car-body and preferably provided at its lower end with an anti-friction roller  $h$ . This arm is arranged to move up and down in a suitable guide I, and is normally held in its upward position by a spring J. The construction of the arm is well shown in Fig. 3, where it is represented as depressed and in the act of striking and forcing down the block E, and also in Fig. 5, where it is shown in its normal upward position, in which it will pass clear of the block E.

Any suitable mechanism may be employed whereby the driver may press down the arm H when he wishes it to strike the block E to open the switch. I have represented for this purpose a yoke-bar K. (Shown at Fig. 6 in its position upon the bottom or under side of the car-platform.) This bar is connected by means of a suitable flexible connection L, passing over guide-pulleys  $l l$ , with the arm H, and the yoke-bar K is adapted, by means

of a vertical rod terminating in a handle, to be swung by the driver to press down the arm H to open the switch.

The operation of the device is as follows:

5 The parts being in their normal position and the switch being closed, the main line will be open, and the cars or other vehicles will ordinarily pass along by that line. If, now, the driver of the car desire to enter upon the side track, he forces down the arm H shortly before it arrives at the projection E, this arm so forced down striking the projection, forcing the block E down, working the lever G, and throwing the switch-rail C, thereby opening the switch. The vehicle then passes onto the side track. The switch is now left open with the forward end of the lever A depressed and its rearward end consequently elevated, thus bringing the projection D above the surface of the track and within the path of the tread of the wheel of the next car that may come. This next car, striking the projection D, will again tilt the lever A, thereby raising the block E and closing the switch. If the car in question is bound for the main track, the switch being thus closed, it will go through without effort on the part of the driver. If, however, it is to be switched off to the side track, this will be done by the driver forcing down the arm H in the manner before described.

It is obvious from the foregoing description that the distance along the rail from the

projection D to opposite the projection E should be slightly greater than the length of the wheel-base of the cars running upon the rail, as otherwise the hind wheel of every car would close the switch before it came to it, thereby defeating the object of the device.

I claim—

1. In a switch of the character described, a tilting switch-operating lever having vertical extensions at its front and rear ends, the distance between its extensions being greater than the wheel-base of the vehicles run upon the road, the rearward extension being located in the line of the path of travel of the wheels of said vehicle, the forward extension being located to one side thereof, and a switch-rail in operative connection with the said forward extension and adapted to be opened or closed as the former is raised or lowered, all substantially as set forth.

2. In a switch of the character described, the combination, with the switch-rail C, of the mechanism for operating the same, consisting of the vertically-movable block or projection E, link F, and lever G, loosely connected to the point of the said switch-rail.

In testimony whereof I have hereunto subscribed my name this 12th day of February, A. D. 1890.

PHILIP B. DOWNING.

Witnesses:

ALEX. P. BROWNE,  
JOHN H. TAYLOR.