

No. 612,008.

Patented Oct. 11, 1898.

C. O. BAILIFF.
SHAMPOO HEAD REST.

(Application filed June 21, 1897.)

(No Model.)

2 Sheets—Sheet 1.

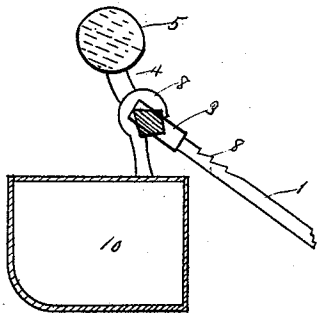
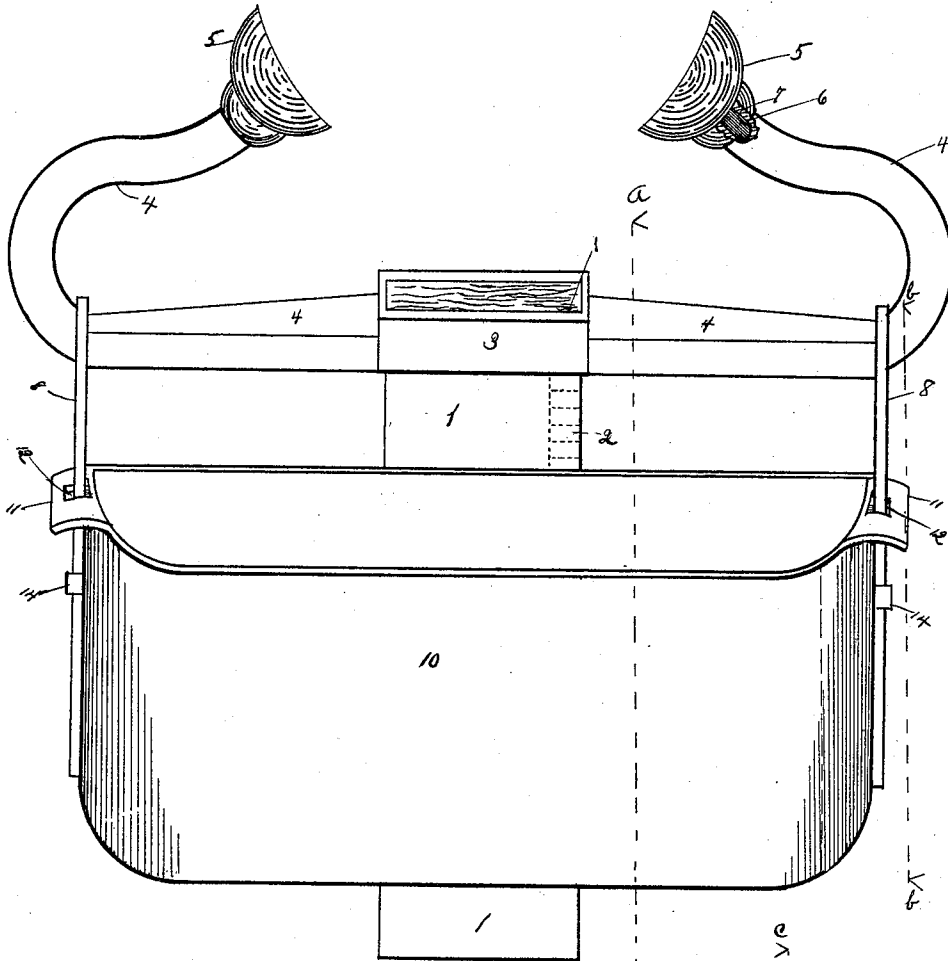

Fig. 2

Fig. 1.

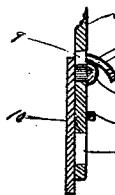

Fig. 3

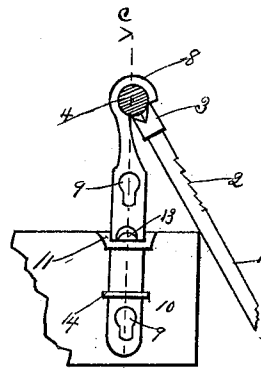

Fig. 4

Witnesses
Chas. P. Sanders.
J. J. Brown

Inventor
Charles Orrin Bailiff
By his Attorney
Thomas W. Stewart

No. 612,008.

Patented Oct. 11, 1898.

C. O. BAILIFF.
SHAMPOO HEAD REST.
(Application filed June 21, 1897.)

(No Model.)

2 Sheets—Sheet 2.

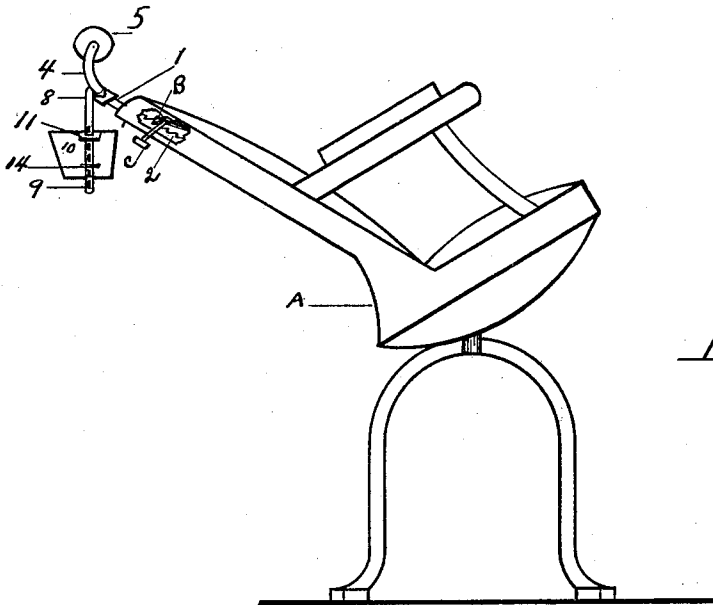

FIG. 5.

Witnesses:

J. J. Stewart
Albert Stewart.

Inventor,

Charles O. Bailiff.
By Thomas W. Stewart.
Att'y.

UNITED STATES PATENT OFFICE.

CHARLES ORREN BAILIFF, OF KALAMAZOO, MICHIGAN.

SHAMPOO HEAD-REST.

SPECIFICATION forming part of Letters Patent No. 612,008, dated October 11, 1898.

Application filed June 21, 1897. Serial No. 641,575. (No model.)

To all whom it may concern:

Be it known that I, CHARLES ORREN BAILIFF, a citizen of the United States, residing at Kalamazoo, in the county of Kalamazoo, State of Michigan, have invented a new and useful Shampoo Head-Rest, of which the following is a specification.

This invention relates to improvements in shampoo head-rest attachments for barber and other chairs, which enable the operator to conveniently and quickly perform the entire work on the head of a person requisite to a complete and perfect shampoo while said person is in the chair and without subjecting him to any inconvenience or discomfort.

One of the objects of this invention is to simplify the method generally adopted in pursuing work of this character, which, according to the present and prevalent custom, requires a part of the operation to be performed on a person in a chair and a part out of a chair, which latter often subjects said person to considerable inconvenience and discomfort by being required to bend over a water-receptacle, where considerable unpleasantness is endured by the water turned or poured upon the head running over the face, into the eyes and other physical organs of the head, all of which my device is designed to obviate.

A further object is to provide a suitable device that can be conveniently and readily attached to and detached from surgical, dental, or other chairs and other means for bodily support which will afford an easy and comfortable head-rest support to persons whose head or any part or any individual member or members thereof is to be operated on in any manner as may be desired by the operator.

Referring to the drawings forming a part of this specification, Figure 1 is a rear elevation in perspective, showing the device complete; Fig. 2, a small transverse side elevation, partly in section, taken on dotted line *a a*, Fig. 1, looking from a point to the left; Fig. 3, a small detail in section taken on dotted line *c c*, Fig. 4; Fig. 4, a small broken detail, partly in section, taken on dotted line *b b*, Fig. 1, looking from a point to the left; and Fig. 5 is a side elevation of a chair with the back reclined, showing my device at-

tached thereto, with a portion of said back broken away, showing means for holding the standard at various points of adjustment.

Describing the parts of the drawings pointed out by numerals, 1 is a standard or post; 2, a rack; 3, a yoke; 4, curved head-supporting arms; 5, hemispherical-shaped pads on the head-supporting ends of the arms; 6, tenons on and integral with the pads; 7, a concave hollow in the head-supporting end of the arms 4 to receive the tenons 6 and hold the pads; 8, suspension-rods for supporting the water-receptacle 10; 9, elongated slots in suspension-rods 8 to permit of the water-receptacle 10 being adjusted either higher or lower; 10, a water-receptacle; 11, handles on and integral with water-receptacle 10; 12, slots in handles 11; 13, headed post or lug projections on the water-receptacle 10, extending horizontally and partly across the slots 12 in handles 11; 14, guides on the side of the water-receptacle 10, through which the lower ends of the suspension-rods 8 pass loosely to prevent said water-receptacle from tilting or tipping.

Referring to Figs. 1 and 5, the device is here shown composed of an ordinary standard 1, provided with a ratchet-notched rack 2, adapted to be attached to chairs A, generally used by barbers, dentists, and surgeons, the backs of said chairs being commonly provided with guides for holding a standard or post bearing a head-rest. The said standard or post is also made adjustable either upward or downward in said guides and held at said points of adjustment by means of a spring ratchet-dog B, having a push-button C attached thereto, fastened in the guides on said chair, engaging in the ratchet-notched rack 2 on the standard 1, after the manner shown in Fig. 5.

Secured to the upper end of the standard 1 is a yoke 3, having partly-curved arms 4 integral with said yoke 3. The head-supporting ends of the arms 4 are concaved and hollow, as shown by the portion broken away at 7, Fig. 1, and are adapted to receive the tenons 6 and the convex portion of the hemispherical pads 5.

The pads 5 may be made of soft rubber or other desirable material that will yield and afford an easy and comfortable cushion to the

head. The concave surfaces of said pads 5 are adapted to receive and conform to any-shaped head that may be supported therein.

The receptacle 10, as shown in Fig. 1 and 5 in section in Fig. 2, is adapted to hold water that may be desired to be used on the head or to catch the water that may be poured or turned upon the head during any operation thereon.

o The flexible suspension-rods 8 are employed to hold the receptacle 10 to the head-supporting arms 4, as shown in Figs. 1, 2, and 4, in which the upper ends of said arms or rods 8 are shown hook shape and hooked over or 5 onto the head-supporting arms 4. The suspension-rods 8 are also provided with a series of elongated holes 9, as shown in Fig. 4 and in vertical section in Fig. 3, which permit of said receptacle 10 being vertically adjusted o either higher or lower, as may be desired, and held firmly at said points of adjustment by the headed lugs 13 on the sides of the receptacle 10, said headed lugs 13 being adapted to pass through the round-eyed portion of the 15 hole 9, and the stem portion of said lug 13 drops down in the elongated portion of the said hole 9, as shown in Fig. 3.

To prevent the receptacle 10 from tilting or tipping from any undue jar, said receptacle 10 is provided with guides 14, as shown in 20 Figs. 1, 3, and 4, through which the lower ends of the suspension-rods 8 loosely pass.

The slots 12 in the handles 11, through which the rods 8 pass, permit of said rods 8 coming 25 into close contact with the sides of the receptacle 10, as shown in Figs. 1, 3, and 4.

Having thus described my invention, what I claim as new, and desire to secure by Letters Patent of the United States, is—

o 1. In a device for the purpose described, a head-rest provided with a suitable head-support, the head-supporting end of said head-support being adapted to be suitably padded or cushioned; a receptacle for holding water 15 adapted to be detachably attached to said head-rest, said water-receptacle being provided with suitable means for adjustment

and for holding said receptacle in an upright position and in proper relation to said head-rest; a post or standard attached to said head- 50 rest, said standard being adapted to be adjustably attached to chairs and other desirable supports, substantially as described and for the purpose set forth.

2. A head-rest provided with one or more 55 head-supporting arms, said head-supporting arms being adapted to be suitably cushioned or padded at their head-supporting ends; a receptacle for holding water or other material adapted to be detachably attached to said 60 head-rest by means of rods or other suitable connections, said receptacle being provided with suitable handles and means for adjustment and for holding said receptacle in an upright position and in proper relation to said 65 head-rest; a standard suitably attached to said head-rest, said standard being adapted to be adjustably attached to chairs and other desirable means of support, substantially as set forth. 70

3. A device for the purpose described, comprising one or more arms of suitable shape adapted to form a suitable head-rest, said arm or arms being centrally connected to a stand- 75 ard; the head-supporting ends of said arms being adapted to be padded or cushioned in a suitable manner; a receptacle for holding water adapted to be detachably attached to said head-rest, said water-receptacle being provided with suitable means for adjustment 80 and for holding said receptacle in an upright position and in proper relation to said head-support; a standard attached to said head-rest, said standard being adapted to be adjustably attached to chairs and other desir- 85 able supports, substantially as described and for the purpose set forth.

In testimony of the foregoing I have hereunto set my hand in the presence of two witnesses.

CHARLES ORREN BAILIFF.

Witnesses:

JOHN W. ADAMS,

EDWARD A. SHIELDS.