

No. 624,192.

Patented May 2, 1899.

J. H. DICKINSON.
REED ORGAN.

(Application filed Aug. 17, 1898.)

(No Model.)

2 Sheets—Sheet 1.

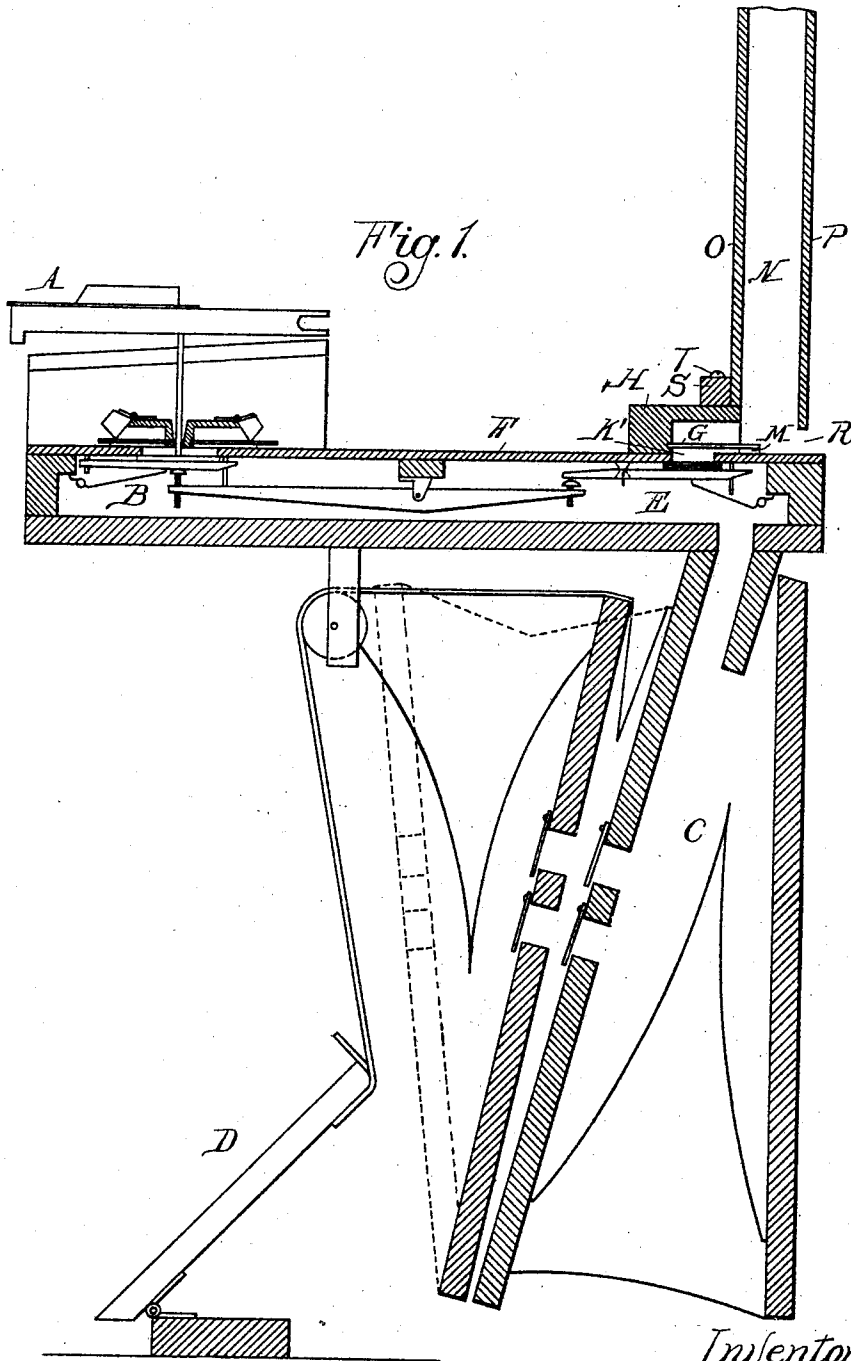

Witnesses:

A. P. Barthel
A. P. Barthel

Inventor:

Joseph H. Dickinson,
By *Smith & Spangner*
Attorneys.

J. H. DICKINSON.
REED ORGAN.

(Application filed Aug. 17, 1898.)

(No Model.)

2 Sheets—Sheet 2.

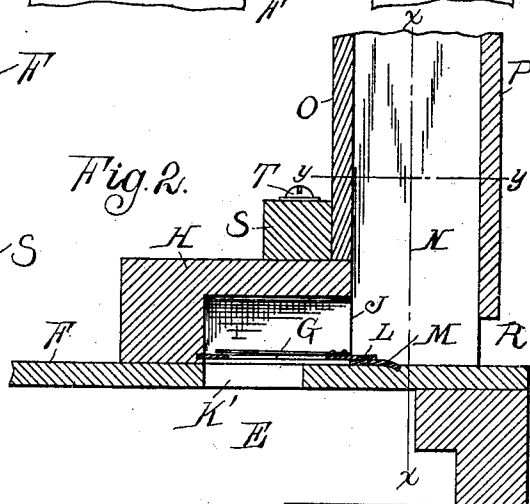
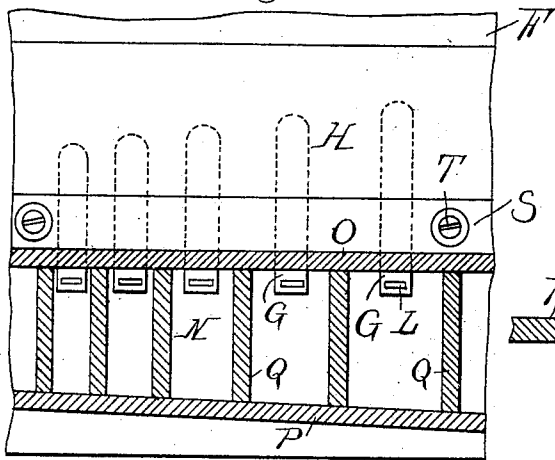
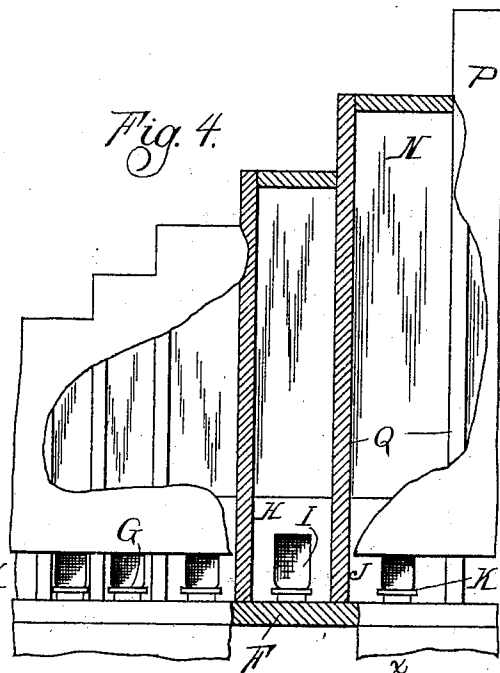
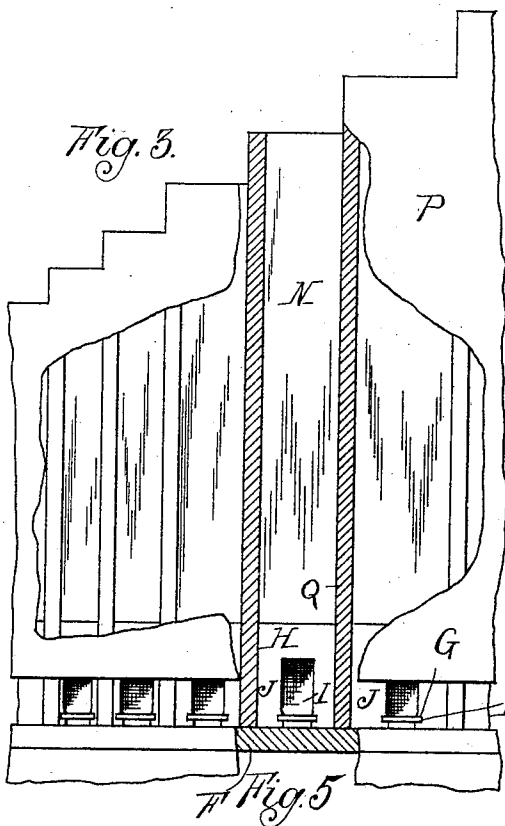

Witnesses:

A. Barthel
A. Barthel

Inventor:

Joseph H. Dickinson,
By *Thos. Magnusson*

Attorneys.

UNITED STATES PATENT OFFICE.

JOSEPH H. DICKINSON, OF DETROIT, MICHIGAN.

REED-ORGAN.

SPECIFICATION forming part of Letters Patent No. 624,192, dated May 2, 1899.

Application filed August 17, 1898. Serial No. 688,750. (No model.)

To all whom it may concern:

Be it known that I, JOSEPH H. DICKINSON, a citizen of the United States, residing at Detroit, in the county of Wayne and State of Michigan, have invented certain new and useful Improvements in Reed-Organs, of which the following is a specification, reference being had therein to the accompanying drawings.

This invention relates more particularly to qualifying-tubes for reed-organs; and the invention consists in the peculiar construction, arrangement, and operation of said tubes, all as more fully hereinafter described, and shown in the drawings, in which—

Figure 1 is a diagrammatic vertical cross-section of a reed-organ of known construction to which I have applied my invention. Fig. 2 is a vertical cross-section of one of the reed-cells and its qualifying-tube, showing these parts on a larger scale than in Fig. 1. Fig. 3 is a rear elevation of Fig. 2, partly in section, in the plane of line *xx* in Fig. 2. Fig. 4 is the same as Fig. 3 except as to the qualifying-tubes being shown as closed on top. Fig. 5 is a horizontal section in the plane of line *yy*, Fig. 2.

A is the keyboard, B the action, C the exhaust-bellows, D the pedals, E the exhaust-chamber, F the sounding-board, and G the reeds, all constructed and arranged to operate in a known manner and forming no part of my invention except as hereinafter described.

H is a reed-block extending transversely on top of the sounding-board and having formed in it individual cells I for the series of reeds G. The cells are made of graduated size, according to the size of the reed, and are entirely separated from each other by the intermediate division-walls J, in which horizontal grooves K are formed, in which the edges of the reed slidingly engage. The cells communicate through openings K' in the sounding-board below the reeds with the exhaust-chamber E and are entirely open at the rear ends. The reeds project slightly beyond the rear end of the cells and have holes L or other suitable means for engaging a hook or suitable key to permit their ready removal if necessary for tuning, a strip of felt M be-

ing interposed between the reed and the sounding-board to form a tight joint.

N are a series of qualifying-tubes, one for each reed. These tubes are mounted in vertical position in rear of the reed-cells, and their front and rear walls at the bottom end are formed with openings or are cut away to form a direct opening from each reed-cell into the bottom end of its respective tube and through said bottom end to the atmosphere directly in line with the cell. The preferable way in which I construct these tubes is in the form of a bank, as shown in the drawings. To this end the front and rear walls of all the tubes are formed unitedly by transverse vertical walls O P, and by means of vertical division-strips Q the space between is divided into vertical flues, which are stepped off at the upper end at proper height. By placing the two walls O P at an angle to each other and spacing the division-strips at suitable distance apart the interior space can be readily divided into flues of appropriate cross-section and height to form proper qualifying-tubes for each of the series of reeds, and in thus constructing these qualifying-tubes it is evident that the cells in the reed-block have to be spaced the proper distances apart to have each cell register with its proper tube.

The preferable way the tubes and cells are made to communicate is by placing the front wall O above the rear end of the reed-block, so that each cell opens directly into the bottom end of its tube, and by stopping off the rear wall P at a distance above the sounding-board an opening R is formed into the bottom end of each tube directly in rear of the reed-cells and suitably large to permit the ready withdrawal of any reed.

The division-strips Q rest on top of the sounding-board, and a base-strip S is secured to the wall O, and by means of screws T the whole bank of tubes is secured in position.

My construction has the advantage of great simplicity and cheapness and permits the ready mounting and dismounting of the bank of tubes as a whole.

In arranging the qualifying-tubes so that the reed-cells communicate with their rear or speaking ends directly into the lower ends

of the qualifying-tubes, so that each tube forms a direct upward continuation of its particular reed-cell and at the same time has a direct open passage or outlet into the air, I do not only gain the advantage of having unobstructed access to each reed, but the quality and volume of the sound is greatly improved, making it similar to that of a diapason-pipe, and by closing the qualifying-tubes at their upper ends, as shown in Fig. 4, the sound is that of a closed diapason-pipe.

What I claim as my invention is—

1. In a reed-organ, a bank of qualifying-tubes comprising a series of division-strips arranged at different distances from each other, the spaces between said strips varying in size the length of the bank, and a front and rear wall placed at an angle to each other forming unitedly the front and rear walls of

the tube, said tubes being stepped off at their upper ends.

2. In a reed-organ, the combination with the sounding-board, the reed-block thereon having formed therein a series of reed-cells, and a series of reeds upon the sounding-board, each extending within its respective cell, of a qualifying device for the reeds consisting of a casing comprising front and rear walls, the front wall resting upon the reed-block, and a series of division-strips between said walls and extending below the latter into contact with the sounding-board.

In testimony whereof I affix my signature in presence of two witnesses.

JOSEPH H. DICKINSON.

Witnesses:

OTTO F. BARTHEL,
A. BARTHEL.