

No. 620,362.

Patented Feb. 28, 1899.

A. C. RICHARDSON.
INSECT DESTROYER.

(Application filed Mar. 7, 1898.)

(No Model.)

2 Sheets—Sheet 1.

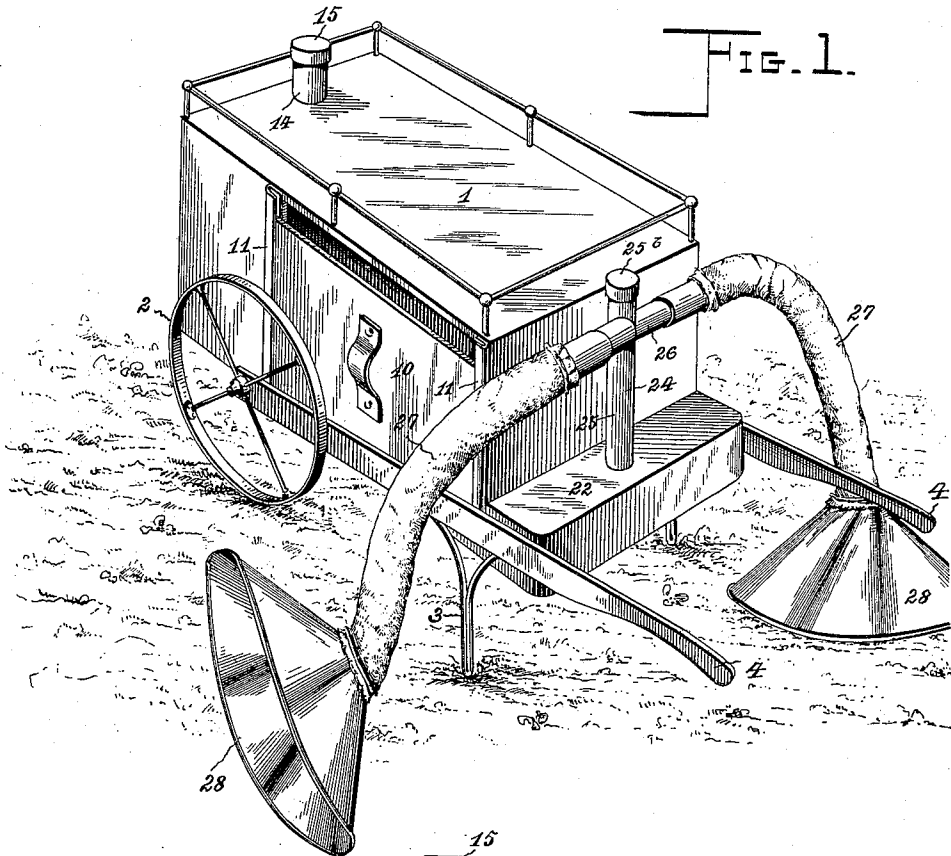

FIG. 1.

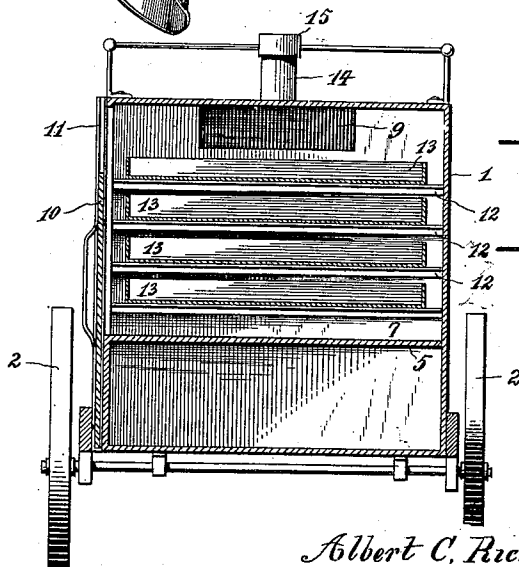

FIG. 3.

Witnesses
John F. Defferwiel
J. F. Riley

Albert C. Richardson, Inventor
By his Attorneys,

Chas. Snow & Co.

No. 620,362.

Patented Feb. 28, 1899.

A. C. RICHARDSON.
INSECT DESTROYER.

(Application filed Mar. 7, 1898.)

(No Model.)

2 Sheets—Sheet 2.

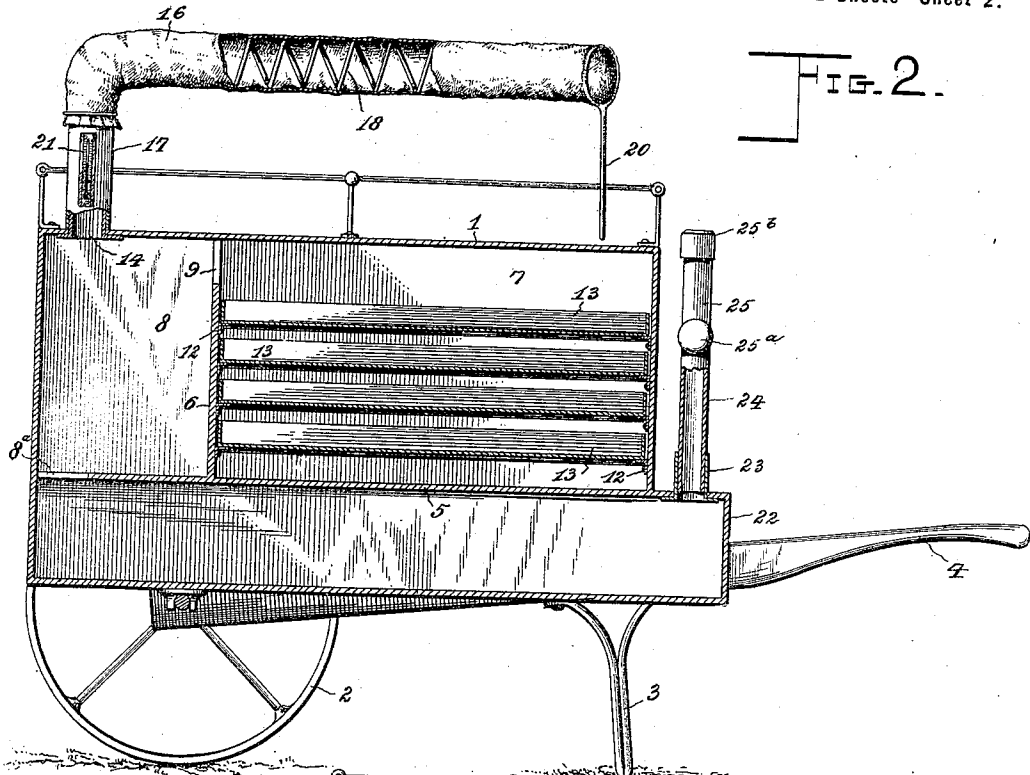

FIG. 2.

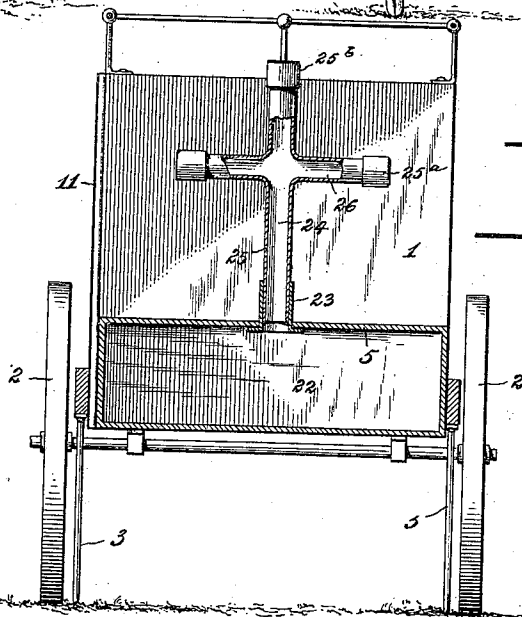

FIG. 4.

Witnesses
John F. Deufferwil
J. G. Riley

By *his* Attorneys,
Albert C. Richardson, Inventor

C. A. Snow & Co.

UNITED STATES PATENT OFFICE.

ALBERT C. RICHARDSON, OF SOUTH FRANKFORT, MICHIGAN, ASSIGNOR OF
ONE-HALF TO AUGUST NATZEL, OF SAME PLACE.

INSECT-DESTROYER.

SPECIFICATION forming part of Letters Patent No. 620,362, dated February 28, 1899.

Application filed March 7, 1898. Serial No. 672,907. (No model.)

To all whom it may concern:

Be it known that I, ALBERT C. RICHARDSON, a citizen of the United States, residing at South Frankfort, in the county of Benzie and State of Michigan, have invented a new and useful Insect-Destroyer, of which the following is a specification.

The invention relates to improvements in insect-destroyers.

The object of the present invention is to improve the construction of insect-destroyers and to provide a simple, inexpensive, and efficient device adapted to destroy insects of plants and trees without injuring the tender shoots or foliage.

The invention consists in the construction and novel combination and arrangement of parts, as hereinafter fully described, illustrated in the accompanying drawings, and pointed out in the claims hereto appended.

In the drawings, Figure 1 is a perspective view of an insect-destroyer constructed in accordance with this invention. Fig. 2 is a longitudinal sectional view. Fig. 3 is a transverse sectional view. Fig. 4 is a vertical sectional view of the cross-shaped coupling, the removable caps being arranged on the arms thereof.

Like numerals of reference designate corresponding parts in all the figures of the drawings.

1 designates a casing, rectangular in section, constructed of sheet metal and mounted at one end upon wheels 2 and at the other end upon legs 3 and provided at the end having the legs with handles 4, so that it is adapted to be moved about similar to a wheelbarrow and conveyed from one part of a field or garden to another. The casing is provided adjacent to its bottom with a horizontal partition 5, forming a false bottom, and the space above the latter is divided by a vertical partition 6, forming a main chamber 7, and a rear compartment 8, adapted to contain ice or water, for the purpose hereinafter described.

The transverse partition 6 is located near the rear end of the casing, and it is provided at its top with an opening 9, forming a passage-way to permit smoke and fumes to pass from the main chamber into the rear compartment. One side of the casing is open

and provided with a sliding door 10, arranged in vertical ways 11 and terminating short of the top of the casing to provide an opening to afford a draft; but as the sliding door when arranged as shown in Figs. 1 and 3 of the accompanying drawings extends below the horizontal partition or false bottom of the casing it is adapted to be moved upward for closing the casing in order to shut off the draft completely.

The main compartment 7 is provided at its front and rear walls with series of horizontal ways 12, adapted to receive pans 13, in which tobacco or other material for producing smoke and fumes is burned. As the draft is admitted at the top of the chamber and passes over the burning material the fire is caused to burn more slowly and to produce a greater quantity of smoke than would be the case were the draft admitted at the bottom of the chamber.

The smoke and fumes resulting from the burning of tobacco or other material passes through the opening 9 of the transverse partition and is adapted to pass out through the top of the casing, which is provided with a tubular vent 14, consisting of a short tube provided with a removable cap 15. The cap is adapted to be removed to uncover the discharge-opening and permit the smoke and fumes to be discharged through a flexible pipe or hose 16, provided at its inner end with a metal sleeve 17 to fit the short tube at the discharge-opening of the top of the casing.

The tube or hose 16 is maintained expanded by a spiral spring 18, arranged within it, so that in moving the flexible tube or hose from one bough or plant to another it will not be constricted by bending, and the discharge of the smoke will be uninterrupted. The discharge tube or hose is provided at its outer end with a handle 20, consisting of a rod provided at its point of attachment to the hose or tube with a ring, and the handle may be of any desired length, so that the smoke and fumes may be discharged upon any portion of a tree or plant.

The smoke is discharged directly from the chamber 7 in a more or less heated condition, and the discharge pipe or hose is provided at its metallic sleeve with a thermometer 21,

adapted to indicate the temperature, so that there will be no liability of scorching the leaves and injuring a tree or plant.

The smoke and fumes, which are adapted
 5 to destroy insects, may be discharged directly upon large and hardy trees; but in order to prevent tender foliage and small plants from being injured by hot smoke the chamber 8 is designed to be provided with ice or water to
 10 form a cooling-chamber, and the smoke is caused to pass through the same and along the bottom of the casing to the front thereof. The floor or bottom of the cooling chamber or compartment is provided with an opening 8^a,
 15 communicating with the space between the bottom of the casing and the horizontal partition or false bottom 5, and the bottom and false bottom are extended forward beyond the front wall of the casing. The extended
 20 portion 22 of the bottom of the casing is provided with a discharge-opening, from which extends a short vertical tube 23, receiving a coupling 24, having substantially the shape of a cross and consisting of a vertical
 25 stem 25 and horizontal arms 26, extending from the stem in opposite directions and adapted to receive removable caps 25^a, and when the vertical stem is not used it is closed by a cap 25^b. The vertical stem is adapted
 30 to receive the discharge pipe or hose 16, and the arms 26 are provided for the purpose of permitting the device to be worked between two rows of plants, and they are adapted to receive a pair of discharge-pipes 27, constructed similar to the discharge pipe or hose
 35 16 and provided at their outer ends with funnel-shaped nozzles or hoods 28, flattened, as shown, and adapted to be placed over a plant to subject the same to the action of the smoke and fumes. The funnel-shaped hoods 28,
 40 which have imperforate sides, are substantially triangular in elevation and are provided with narrow elongated bases to adapt them to be used to greater advantage in operating on rows of plants. As the discharge-pipes 27 extend from opposite sides of the device, as clearly illustrated in Fig. 1 of the accompanying drawings, it will be clear that the plants of two rows will be simultaneously
 50 operated on. The cap 15 is adapted to prevent the escape of smoke through the discharge-opening of the top of the casing, and it causes the said smoke and fumes to pass through the cooling-chamber, so that the temperature of the smoke will be reduced sufficiently to prevent the tenderest plants or foliage from being injured.

The invention has the following advantages: The insect-destroyer, which is simple
 60 and comparatively inexpensive in construction, is adapted to discharge smoke and fumes upon insects infesting trees and plants, and the smoke and fumes may be discharged directly from the main chamber, or they may be
 65 passed through the cooling-chamber and lowered in temperature, so that they will not injure the tenderest foliage or plants. The de-

vice is also adapted to work between rows, and it is capable of simultaneously subjecting the plants of two rows to the treatment. 70 The draft is admitted at the top of the main chamber and caused to pass over the pans of burning material, and the sliding door may be also arranged for shutting off the draft entirely. It is adapted to vary the size of the
 75 draft-opening, so that the burning may be regulated perfectly.

Changes in the form, proportion, and minor details of construction may be resorted to without departing from the spirit or sacrificing any of the advantages of this invention. 80

What I claim is—

1. An insect-destroyer comprising a casing provided with a main chamber for containing burning material and having a cooling-chamber, 85 said casing being provided with discharge-openings at opposite sides of the cooling-chamber, whereby smoke may be directly discharged from the casing or caused to pass through the cooling-chamber, substantially
 90 as and for the purpose described.

2. An insect-destroyer comprising a casing provided with a chamber for containing burning material and having a cooling-chamber, 95 said casing being provided with discharge-openings located at points at opposite sides of the cooling-chamber, so that smoke may be discharged directly from the casing or caused to pass through the cooling-chamber, a discharge pipe or hose adapted to be connected
 100 with either discharge-opening, and a cap adapted to cover the opening for the direct discharge of smoke, substantially as described.

3. An insect-destroyer comprising a casing 105 having a main chamber for containing burning material, a cooling-chamber and a sliding door at one side of the main chamber to provide an opening at the top thereof, and pans or trays arranged within the main chamber
 110 in suitable supports or ways, substantially as described.

4. An insect-destroyer comprising a casing provided with a main chamber and having a 115 cooling-chamber located at one end of the main chamber, said casing being provided beneath the main chamber and the cooling-chamber with a space forming a smoke-conduit and communicating with the cooling-chamber at the bottom thereof, vents arranged
 120 at the top of the casing and at the front thereof, the vent at the top being adapted for the direct discharge of smoke and the other vent communicating with the space at the bottom of the casing, and a discharge pipe or tube
 125 adapted to be connected with either vent, substantially as described.

5. An insect-destroyer comprising a casing, a horizontal partition arranged adjacent to the bottom of the casing, a vertical partition 130 dividing the casing into a main chamber and a cooling-chamber, the cooling-chamber communicating at its top with the main chamber and at its bottom with the space below the

horizontal partition, and vents arranged at the top of the cooling-chamber and at the bottom of the casing to communicate with the space beneath the horizontal partition, substantially as described.

5 6. An insect-destroyer comprising a casing, a horizontal partition arranged adjacent to the bottom of the casing, a vertical partition dividing the casing into a main chamber and
 10 a cooling-chamber, a series of pans arranged within the main chamber, a sliding door arranged at one side of the main chamber and adapted to form a draft-opening at the top thereof, and a discharge-tube adapted to be
 15 connected with the top of the casing and with the space beneath the horizontal partition, substantially as described.

7. An insect-destroyer comprising a casing provided with a main chamber and having a
 20 cooling-chamber and provided with vents arranged to discharge smoke directly from the casing and to cause the same to pass through the cooling-chamber, a coupling connected
 25 ally-extending arms, and discharge-pipes con-

nected with the arms of the coupling and provided with hoods adapted to be placed over plants, substantially as described.

8. An insect-destroyer comprising a casing having a cooling-chamber and provided at
 30 one end with handles and having legs depending from it adjacent to the handles, wheels mounted on the casing at the other end thereof, and a discharge pipe or tube connected
 35 with the casing, substantially as described.

9. An insect-destroyer comprising a casing having a main chamber and provided with a cooling-chamber, a substantially cross-shaped coupling mounted on the casing and connect-
 40 ed with the cooling-chamber and consisting of a vertical stem and horizontal arms adapted to be closed by removable caps, and a discharge pipe or tube, substantially as described.

In testimony that I claim the foregoing as my own I have hereto affixed my signature in
 45 the presence of two witnesses.

ALBERT C. RICHARDSON.

Witnesses:

JACOB MAY,
 N. AUGUSTUS PARKER.