

J. R. WINTERS.  
Fire-Escape Ladder.

No. 203,517.

Patented May 7, 1878.

Fig. 1.

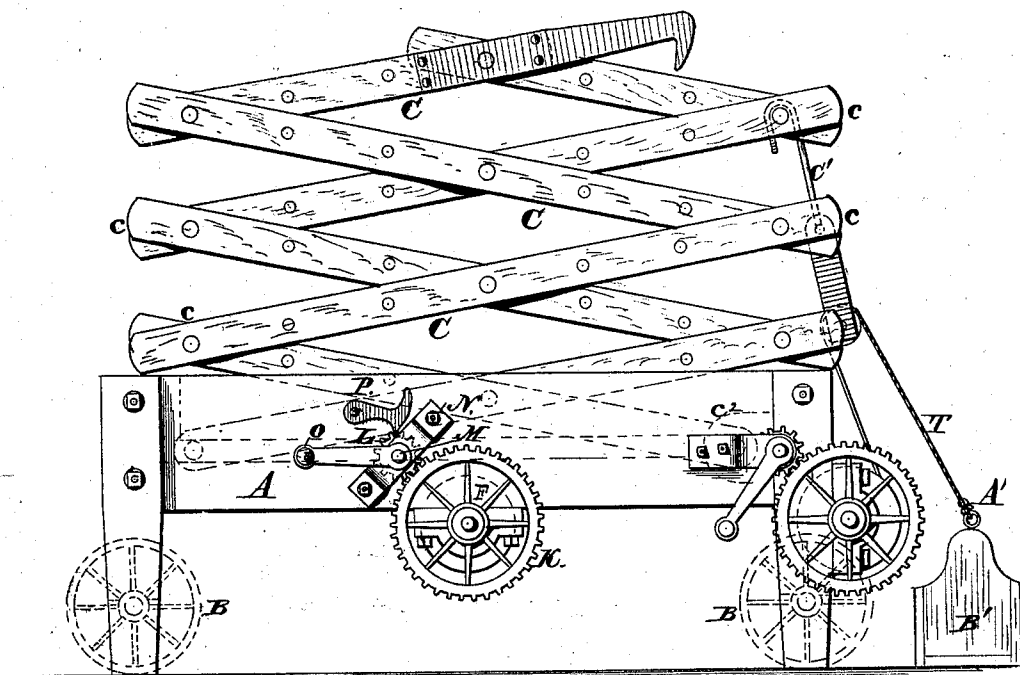
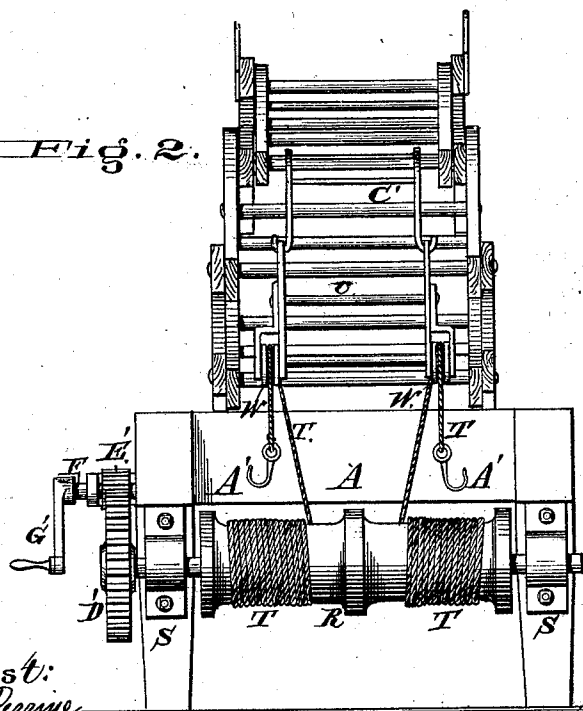

Fig. 2.



Attest:  
H. L. Peckham

J. A. Rutherford

Joseph R. Winters.  
Inventor.

By James L. Norris,  
Atty.

J. R. WINTERS.  
Fire-Escape Ladder.

No. 203,517.

Patented May 7, 1878.

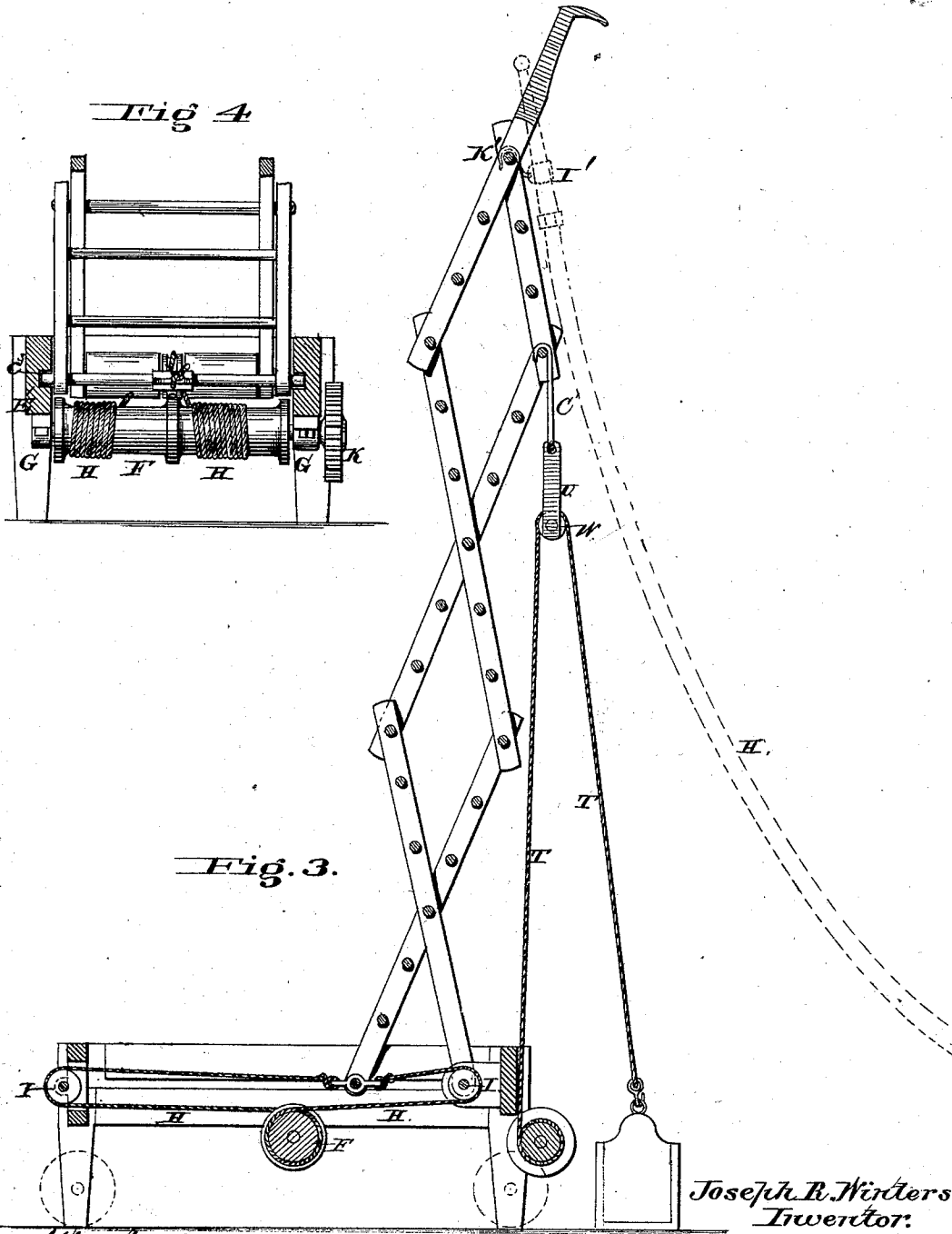

Joseph B. Winters  
Inventor.

Attest  
H. L. Perine  
J. A. Ritterford

By James L. Norris  
Atty.

# UNITED STATES PATENT OFFICE.

JOSEPH R. WINTERS, OF CHAMBERSBURG, PENNSYLVANIA, ASSIGNOR OF ONE-FOURTH HIS RIGHT TO JOHN H. OYLER AND THEODORE MCGOWAN, OF SAME PLACE.

## IMPROVEMENT IN FIRE-ESCAPE LADDERS.

Specification forming part of Letters Patent No. **203,517**, dated May 7, 1878; application filed December 28, 1877.

*To all whom it may concern:*

Be it known that I, JOSEPH R. WINTERS, of Chambersburg, in the county of Franklin and State of Pennsylvania, have invented certain new and useful Improvements in Firemen's Ladder and Fire-Escape, of which the following is a specification:

This invention relates to an improved ladder-truck and fire-escape, its object being to provide an apparatus that may be readily transported from place to place, and by means of which a series of ladders may be expeditiously raised to the upper stories of a burning building without dismounting said ladders from the truck, whereby provision is made for the access of the firemen to any portion of such building with the various appliances for extinguishing the fire, as well as for the escape of any persons in the upper stories of the building, whose escape may be cut off by the flames in the lower stories thereof.

To this end my invention consists in a series of ladder-sections, forming a folding ladder, said sections being pivoted together at their ends and midway between said ends, with the exception of the ends of the lower sections, the lower end of one of said lower sections being pivoted to the frame of the truck, and the end of the other of said lower section being provided with projections adapted to travel in longitudinal ways formed in the frame of the truck, the said movable section being connected, by means of suitable ropes, chains, or cables, with a windlass having its bearings in the frame, by means of which the ladder-sections may be extended or folded together, as more fully hereinafter specified.

In the drawings, Figure 1 represents a side elevation of my improved apparatus, showing the ladder in a folded position. Fig. 2 represents an end elevation of the same. Fig. 3 represents a longitudinal vertical section, showing the ladder in an extended position; and Fig. 4, a transverse vertical section of the same.

The letter A represents a truck-frame, constructed of any suitable material, mounted upon wheels B for convenient transportation;

and C, a series of ladder-sections, forming a folding and extensible ladder. The said sections are pivoted together at the ends *c*, with the exception of the two lower sections, the end of one of said lower sections being pivoted to the truck-frame at one end, as shown at *c*<sup>2</sup>, while the end of the other lower section is provided with pins or projections *c*<sup>3</sup>, which set and are adapted to travel in horizontal ways or grooves E, formed in the truck-frame A.

The letter F represents a windlass extending transversely across the truck-frame at about its center, and journaled at suitable bearings, G, in said frame. Said windlass is provided with a double drum, to which are secured the reversely-wound ropes, chains, or cables H, which are attached to the lower round of the lower movable ladder-section, and pass over pulleys I, located at each end of the truck-frame A, in such manner that as the windlass is rotated the lower movable ladder-section will be caused to travel in the ways or grooves in the truck-frame, so as to extend or fold the ladder according to the direction in which the windlass is rotated. The said windlass is provided at one end of its journal with a gear-wheel, K, which meshes with a pinion, L, mounted on a crank-shaft, M, journaled at one end in the frame A, and at the other in a bracket, N, attached to said frame at one side, the said crank-shaft being provided with a crank, O, by means of which it may be operated.

The letter P represents a dog or pawl, pivoted to the frame A in such position that its end may be made to engage the pinion L, and hold the drum in position to secure the ladder at any desired elevation.

The letter R represents a windlass journaled in bearings S at one end of the truck-frame, and provided with a double drum, upon which are wound the ropes, chains, or cables T; and U represents a detachable frame, provided with pulleys W, over which said ropes, chains, or cables pass, the free ends of said ropes, chains, or cables being provided with hooks A', by means of which a bucket or elevator, B', may be attached thereto. Said frame is also provided

with a hooked link or frame, C', by means of which it may be secured to any of the rounds of the ladder, whereby provision is made for elevating the bucket or elevator to any desired point, by means of the ropes, chains, or cables and the windlass. The shaft of said windlass is provided with a gear-wheel, D', at one end, which meshes with a pinion, E', or a crank-shaft, F', which is provided with a crank, G', by which said windlass may be operated.

The letter H' represents a hose provided with a hose-pipe, I', and a coupling, the latter of which may be attached to a hydrant or the delivery-pipe of a fire-engine or pump. The hose-pipe I' is provided with a hooked link, K', by means of which it may be attached to one of the rounds of the ladder-sections, so as to be elevated with the ladder and brought within convenient reach of the firemen.

The end of one of the upper sections of the ladder may be provided with hooks N', by means of which it may be secured to a window or other portion of the burning building, to assist in holding the sections in a properly-extended position.

The operation of my invention will be readily understood in connection with the above description. Upon the occurrence of a fire the truck may, as will be perceived, be rapidly transported to its place, and upon its arrival the ladder can be quickly extended to the desired height, offering a ready means of

access of the firemen to the fire, as well as a means of escape to any persons confined in the upper portions of the building.

By means of the bucket or elevator provision is made for carrying up water to the burning portions of the building, as well as for lowering valuables, or persons too helpless to make their escape by the ladders, while, by means of the hose and its hose-pipe, provision is made for elevating said pipe to any convenient point, so as to provide for the play of a stream of water upon the burning portions of the building.

What I claim, and desire to secure by Letters Patent, is—

The combination, with the rigid truck-frame, of a folding ladder, consisting of a series of pivoted sections, one of the lower sections of which is pivoted fast in one end of frame, and the other provided with projections adapted to travel in the ways on the rigid truck-frame, and the windlass and the two reversely-wound ropes or chains, each passing around a pulley, I, in the end of the truck-frame, and connected to the lower round of the traveling ladder-section, substantially as described.

In testimony that I claim the foregoing I have hereunto set my hand in the presence of the subscribing witnesses.

JOSEPH R. WINTERS.

Witnesses:

C. M. DUNCAN,  
THEODORE MCGOWAN.